

**Ministry of Health of the Republic of Belarus
Educational institution
"Gomel State Medical University"**

Department of General and Bioorganic Chemistry

Author:

A.K. Dovnar, senior lecturer of the Department
of General and Bioorganic Chemistry

METHODOLOGICAL MANUAL

for conducting the laboratory class with the first-year students
of the Faculty of International Students
studying in the specialty 7-07-0911-01 "Medical business" (FIS)
English-speaking students
in the discipline "Medical chemistry"

Topic 7: **ELECTRODE AND REDUCTION POTENTIALS**

Time: 2 hours

Gomel, 2023

THE TRAINING AND EDUCATIONAL GOALS, MOTIVATION TO STUDY THE TOPIC

The purpose of the class:

To familiarize students with the theoretical bases of electrochemistry and the use of electrochemical methods, in particular potentiometry, in biomedical research. To teach experimental determination of pH of solutions and potentiometric titration of solutions.

The tasks of the class:

As a result of the class, the student *must know*:

- 1) the structure and operation of galvanic cells, their types;
- 2) mechanisms of occurrence of electrode, redox, diffusion and membrane potentials;
- 3) types of electrodes used in potentiometry;
- 4) the essence of direct potentiometry and potentiometric titration; the application of potentiometric investigations for analysis of biological systems.

The student *must be able to*:

- 1) calculate EMF and equilibrium constant under standard conditions for redox reactions and predict their direction;
- 2) perform typical calculations using the Nernst's equation;
- 3) write a cell diagram of the galvanic cells;
- 4) calculate the EMF of galvanic cells.
- 5) determine concentrations of weak acids in solutions and ionization constants by the potentiometric method.

Motivation to study the topic:

Potentiometry methods are used in clinical analysis and in the practice of sanitary and hygienic research. Using potentiometric methods, it is possible to determine the concentration of physiologically active ions (H_3O^+ , K^+ , Na^+ , Ca^{2+} , NH_4^+ , Cl^- , Br^- , I^-) in biological fluids and tissues. When using enzyme electrodes, glucose, urea, amino acids and other metabolites can be determined, and with the help of gas electrodes, the state of the air environment can be monitored. Potentiometric titration is used to determine the concentration of biologically active and medicinal substances.

The study of the mechanisms of the occurrence of electrode and redox potentials makes it possible to understand the features of many biochemical processes in the body, in particular, the processes of biological oxidation. The method of recording biopotentials is used in the study of the activity of various organs, for example, in the diagnostics of heart diseases (electrocardiography). Registration of brain biopotentials (electroencephalogram) in some cases makes it possible to determine pathological disorders of the central nervous system. When studying the phenomena of excitation in muscles and coordination of muscular activity in athletes, the method of sequential registration of a number of individual currents of muscle action (electromyography) is used.

Medical students should know that some materials are widely used in medical practice, in particular, metals used for endoprosthetics of bone tissues and teeth. A significant disadvantage of these materials is that when they are introduced into the body at the metal-solution interface, a potential jump is formed and electrochemical processes are generated.

NECESSARY EQUIPMENT

1. Methodological manual for students on the topic "Electrode and reduction potentials".
2. Reference materials of physico-chemical constants for the 1st year education international students.
3. Chemical reagents and equipment necessary for laboratory work.

CONTROL QUESTIONS ON THE TOPIC OF THE CLASS

1. The reduction potential is a measure of the strength of oxidants and reductants in aqueous solutions. The Nernst's equation. Prediction of the direction of redox reactions.
2. The structure and operation of galvanic cells (using the example of the Daniel's cell), their types. Electrode and diffusion potentials. Galvanic cell diagrams. Calculation of the EMF of a galvanic cell. Membrane potentials (biopotentials), their calculation.
3. Potentiometry: direct (ionometry) and indirect (potentiometric titration). Types of electrodes used in potentiometry.

COURSE OF THE CLASS

The theoretical part

1. THE REDUCTION POTENTIAL IS A MEASURE OF THE STRENGTH OF OXIDANTS AND REDUCTANTS IN AQUEOUS SOLUTIONS. THE NERNST EQUATION. PREDICTION OF THE DIRECTION OF REDOX REACTIONS

Redox reactions are electron transfer reactions. In redox reactions, electrons move from one species to another. The equation for the intermolecular redox reaction can be represented as follows:

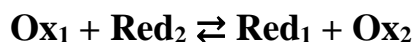

$\text{Ox}_1 | \text{Red}_1$ and $\text{Ox}_2 | \text{Red}_2$ are conjugate pairs of oxidizing and reducing agents.

In general, the stronger the reducing agent, the weaker the corresponding oxidizing agent that is formed on the other side of an oxidation step.

Reduction potentials ($\varphi_{\text{Ox}|\text{Red}}$, V) are used to express the strength of oxidizing and reducing agents in aqueous solutions. Standard reduction potentials (measured under standard conditions) are denoted as $\varphi^{\circ}_{\text{Ox}|\text{Red}}$, their numerical values are in the range from -3 V up to $+3$ V, may be taken from Reference Tables.

Thus, to estimate the activity of reducing or oxidizing agents, it is necessary to compare values their reduction potentials. The following rule can be used to predict: who – oxidizers or reducing agents are weaker or stronger:

a) the lower the reduction potential, the stronger the reducing agent and the weaker its conjugate oxidizing agent;

A conjugate pair $\text{Li}^+ | \text{Li}$ ($\varphi^{\circ}_{\text{Li}^+|\text{Li}} = -3.045$ V) exhibits the minimum standard potential, so Li is the strongest reducing agent and Li^+ is the weakest oxidizing agent in an aqueous solution.

b) the higher the reduction potential, the stronger the oxidizing agent and the weaker its conjugate reducing agent.

A conjugate pair $F_2 | 2F^-$ exhibits the maximum standard potential (+ 2.87 V), thus F_2 is the strongest oxidizing agent and F^- is the weakest reducing agent in an aqueous solution.

As a rule, oxidizers have positive values of reduction potentials, while reducers have negative values of reduction potentials.

The oxidizing and reducing strength of substances depends upon their:

- nature (electronic structure);
- concentration;
- temperature;
- sometimes acidity of solutions.

The Nernst's equation reflects effects of temperature and concentration on redox properties of oxidizing and reducing agents:

$$\varphi_{Ox/Red} = \varphi^0_{Ox/Red} + \frac{R \times T}{n \times F} \times \ln \frac{[Ox]}{[Red]}$$

R – a gas constant (8.31 J/mol×K);

n – a number of gained or lost electrons;

F – the Faraday's constant (96500 C/mol).

At a standard temperature (298 K), the Nernst's equation may be rearranged:

$$\varphi_{Ox/Red} = \varphi^0_{Ox/Red} + \frac{0.0592}{n} \times \log \frac{[Ox]}{[Red]}$$

If the reduction potential characterizes the half-reaction, the **electromotive force (EMF or E, V)** is a characteristics of the general redox process. This is the difference between the reduction potentials of two conjugated pairs involved into the same electrochemical process:

$$E = \varphi_{Ox_1/Red_1} - \varphi_{Ox_2/Red_2}$$

The electromotive force of the redox reaction serves as a criterion for its spontaneity, since it is associated with Free Energy change ($\Delta_r G$): $\Delta G = -n \times F \times E$

If $E > 0$, $\Delta_r G < 0$ the reaction is spontaneous;

If $E < 0$, $\Delta_r G > 0$ the reaction is nonspontaneous.

The vast majority of oxidation-reduction reactions are reversible so, the **equilibrium constant (K)** is an important characteristic of them.

Since $\Delta_r G^0 = -n \times F \times E^0$; $\Delta_r G^0 = -R \times T \times \ln K$

Therefore,

$$n \times F \times E^0 = R \times T \times \ln K; \quad \ln K = \frac{n \times F \times E^0}{R \times T}; \quad K = e^{\frac{n \times F \times E^0}{R \times T}}$$

When a reaction occurs under standard temperature (T = 298 K):

$$K = 10^{\frac{n \times E^0}{0.0592}}$$

Problem 1. For the following redox reaction:

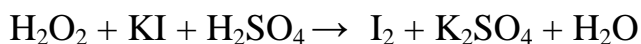

- a) write the half reactions and the balanced equation for the whole reaction;
 b) calculate the EMF, the change in Free Energy, and the equilibrium constant under standard conditions and predict whether the reaction would occur spontaneously under standard conditions and what is direction of the reaction.

The standard reduction potentials for conjugate pairs are:

$$\varphi^0(\text{H}_2\text{O}_2 | \text{H}_2\text{O}) = + 1.77 \text{ V}; \quad \varphi^0(\text{I}_2 | 2\text{I}^-) = + 0.54 \text{ V}$$

Solution:

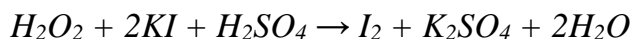
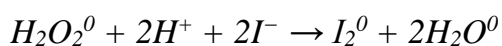
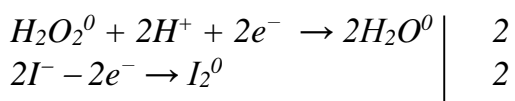
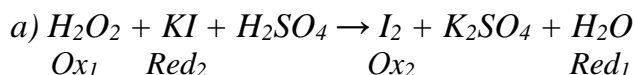

b) $E^0 = \varphi^0(\text{H}_2\text{O}_2 | \text{H}_2\text{O}) - \varphi^0(\text{I}_2 | 2\text{I}^-) = 1.77 - 0.54 = 1.23 \text{ V}$; since $E^0 > 0$, therefore, this reaction proceeds spontaneously under standard conditions;

$$\Delta G^0 = -n \times F \times E^0 = -2 \times 96500 \times 1.23 = -237390 \text{ J}$$

$K = 10^{\frac{2 \times E^0}{0.0592}} = 10^{\frac{2 \times 1.23}{0.0592}} = 10^{41.55} = 3.58 \times 10^{41}$; since $K \gg 0$, therefore, the equilibrium of the reaction is completely shifted to the right side.

2. THE STRUCTURE AND OPERATION OF GALVANIC CELLS (USING THE EXAMPLE OF THE DANIEL CELL), THEIR TYPES. ELECTRODE AND DIFFUSION POTENTIALS. GALVANIC CELL DIAGRAMS. CALCULATION OF THE EMF OF A GALVANIC CELL. MEMBRANE POTENTIALS (BIOPOTENTIALS), THEIR CALCULATION

Galvanic cell is a device that converts the chemical energy of spontaneous redox reactions into electrical energy.

A galvanic cell consists of two half-cells. In its simplest form, each half-cell has an electrode (a metal bar) which is placed in solution of a salt of the metal. Two electrodes are connected by a metallic wire – external circuit; the solutions are connected by a salt bridge (concentrated electrolyte solution) – internal circuit. The salt bridge is necessary to maintain the charge neutrality of each half-cell by allowing ions from one half-cell to move to the other half-cell.

The electrode at which oxidation takes place is called anode; it has a negative potential with respect to the solution. The electrode at which reduction takes place is called cathode; it has a positive potential with respect to the solution.

To determine which metal is the cathode, which metal is the anode, it is necessary to compare the standard reduction potentials of metals. The anode has a lower reduction potential.

When a galvanic cell is functioning electrons move through the external wire from the anode (-) to the cathode (+), producing an electric current.

EMF of a galvanic cell is equal to: $E = \varphi (\text{cathode}) - \varphi (\text{anode})$

Daniel's cell is an example of galvanic cell which converts chemical energy into electrical energy. Daniel's cell consists of zinc and copper electrodes immersed into solutions of their salts. In Daniel's cell, copper ions are reduced at cathode while zinc is oxidized at anode.

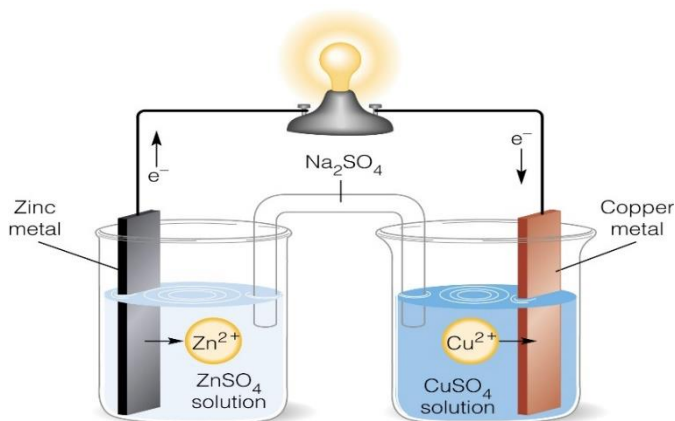
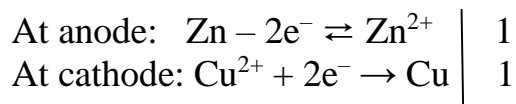

Figure 1 – Scheme of Daniel's galvanic cell

The zinc bar is an anode; oxidation occurs on its surface: $\text{Zn} - 2\text{e}^- \rightleftharpoons \text{Zn}^{2+}$. The electrons lost by the zinc pass through the external wire to the copper electrode, while Zn^{2+} cations diffuse into the solution. As a result, the solution acquires a positive charge, and the metal electrode acquires a negative charge.

The copper bar is a cathode; a reduction occurs on its surface: $\text{Cu}^{2+} + 2\text{e}^- \rightleftharpoons \text{Cu}$. Cu^{2+} cations contained in the solution gain electrons from external circuit, reducing into atoms, and precipitate on the electrode. As a result, the solution gains a negative charge, and the electrode gains a positive charge.

The reactions of the Daniel's cell at the anode and cathode are:



The overall cell reaction involves the reduction of Cu^{2+} ions by Zn metal:

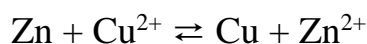

The components of a galvanic cell are represented as **cell diagrams**. For the Daniel's cell it may be described as follows:

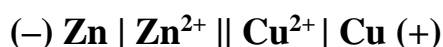

The single vertical line (|) represents a phase boundary between metal and its solution, and a reduction potential generated at the interface surface.

The double vertical line (||) denotes the salt bridge, and a diffusion potential generated at the interface surface of two solutions.

Problem 2. Calculate the EMF for the Daniel's galvanic cell. The standard reduction potentials for metals are:

$$\varphi^0(\text{Cu}^{2+} | \text{Cu}) = + 0.337 \text{ V}$$

$$\varphi^0(\text{Zn}^{2+} | \text{Zn}) = - 0.762 \text{ V}$$

Solution:

$$E^0 = \varphi^0(\text{Cu}^{2+} | \text{Cu}) - \varphi^0(\text{Zn}^{2+} | \text{Zn}) = + 0.337 - (-0.762) = 1.099 \text{ V}$$

Since E^0 has a positive value, the reaction: $\text{Zn} + \text{Cu}^{2+} \rightleftharpoons \text{Cu} + \text{Zn}^{2+}$ is spontaneous in the Daniel's galvanic cell.

Classification of galvanic cells:

- *chemical cells* consist of different electrodes;
- *concentration cells* consist of two identical electrodes and differ in electrolytes' concentrations only;
- *in fuel cells*, energy of combustion is converted into electrical energy.

Beside reduction potentials, membrane potentials can drive electricity production in galvanic cells. The membrane potential appears in response to different concentrations of ions across the membrane. This distribution of ions is typical for cell membranes of the human body.

Table 1 – Distribution of ions on opposite sides of the membrane of a typical nerve cell

Ion	Intracellular	Extracellular
K ⁺	150 mmol/l	5 mmol/l
Na ⁺	15 mmol/l	150 mmol/l
Cl ⁻	10 mmol/l	110 mmol/l

The Nernst's equation for the membrane potential is:

$$\varphi = \frac{R \times T}{n \times F} \times \ln \frac{[X]_{\text{external}}}{[X]_{\text{internal}}}$$

$[X]_{\text{external}}$ and $[X]_{\text{internal}}$ are concentrations of an ion in external and internal media;
n is an electric charge of an ion.

The membrane potentials of living cells are named biopotentials. The transmembrane potential difference plays an important role in the transmission of nerve impulses. The Electrocardiographic Method is a powerful tool of identifying heart defects. It is based on measuring of heart muscle biopotentials [1-3].

3. POTENTIOMETRY: DIRECT (IONOMETRY) AND INDIRECT (POTENTIOMETRIC TITRATION). TYPES OF ELECTRODES USED IN POTENTIOMETRY

Potentiometry is an investigation method based on determination of the EMF of a specially constructed galvanic cells. Potentiometry can be of two types:

- *direct (pH of solutions measuring);*
- *indirect (potentiometric titration).*

The types of electrodes applied in potentiometry:

a) metal electrodes – a metal bar immersed in a solution containing cations of the same metal. For example: $\text{Cu} | \text{Cu}^{2+} (\text{aq}); \text{Zn} | \text{Zn}^{2+} (\text{aq})$.

The electrode reactions are: $\text{Me}^{n+} (\text{aq}) + n\text{e}^- \rightleftharpoons \text{Me} (\text{s})$

Their reduction potentials: $\varphi = \varphi^0 + \frac{0.0592}{n} \times \log[\text{Me}^{n+}]$

Me^{n+} is a potential determining ion

b) metal-insoluble salt electrodes – a metal bar coated with its insoluble salt and immersed in a solution containing the anion of the salt.

An example is the *silver-silver chloride electrode*: $\text{Ag}, \text{AgCl} | \text{KCl}(\text{aq})$.

The electrode reaction is: $\text{AgCl} + \text{e}^- \rightleftharpoons \text{Ag} + \text{Cl}^-$;

$\varphi = \varphi^0 - 0.0592 \times \log [\text{Cl}^-]$

c) gas electrodes

An example is the *standard hydrogen electrode (SHE)*: $\text{Pt}, \text{H}_2 | 2\text{H}^+\text{aq}$

The electrode reaction is: $2\text{H}^+ + 2\text{e}^- \rightleftharpoons \text{H}_2$

$\varphi = \varphi^0 + 0.0592 \times \log[\text{H}^+]$ or $\varphi = -0.0592 \times \text{pH}$

The standard hydrogen electrode is applied to determine the standard reduction potential of any other electrodes.

d) ion-selective electrodes

An example is a *glass electrode* specific to H^+ ions (Fig. 2).

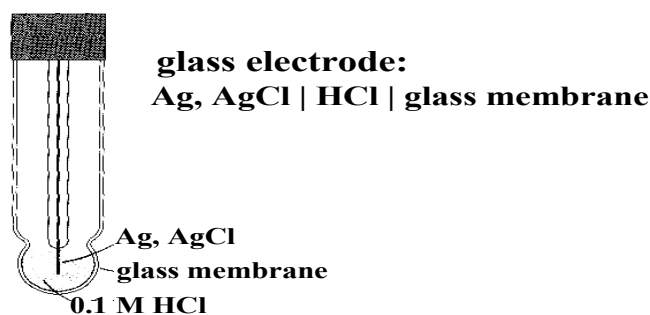

Figure 2 – Glass electrode

It consists of a very thin bulb or membrane made of a special type of glass permeable to H^+ ions. The $\text{Ag} | \text{AgCl}$ electrode is immersed in 0.1 M HCl solution with constant pH equal to 1. When the electrode is placed in a solution whose pH is different from 1, the potential difference between the two sides is a measure of the difference in the two pH values. The following equations relate membrane potential of the glass electrode to acidity of a test solution:

$\varphi_{\text{gl}} = \varphi_{\text{gl}}^0 + 0.0592 \times \log [\text{H}^+]$ or $\varphi_{\text{gl}} = \varphi_{\text{gl}}^0 - 0.0592 \times \text{pH}$

Direct potentiometry: potentiometric pH determination.

The galvanic cell used to determine pH consists of two electrodes: a glass electrode (as an indicator electrode) sensitive to the concentration of hydrogen ions in solution, and a silver-silver chloride electrode (as a reference electrode):

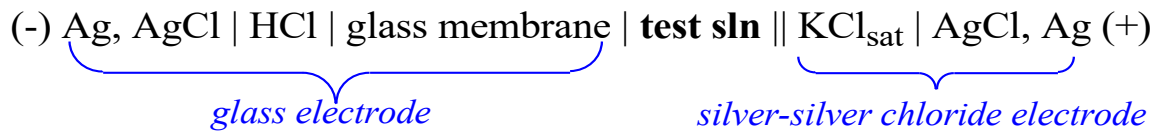

Potentiometric titration is a volumetric method in which the EMF between two electrodes (reference and indicator electrode) is measured as a function of the added titrant volume. The volume of the consumed titrant at the equivalence point is determined graphically by the potentiometric titration curve: integral or differential.

The integral potentiometric titration curve is a plot of potential as a function of the volume of the added titrant. The end point of the reaction is half way between the jump in voltage.

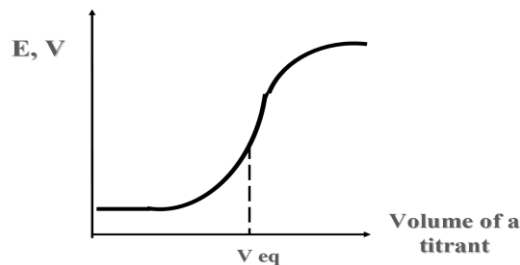

Figure 3 – Integral curve of potentiometric titration

The differential titration curve is used for very precise determination of the end-point of titration. The first derivative, $\Delta E/\Delta V$, is the slope of the curve, and the endpoint occurs at the volume, V_{eq} , where $\Delta E/\Delta V$ has the maximum value.

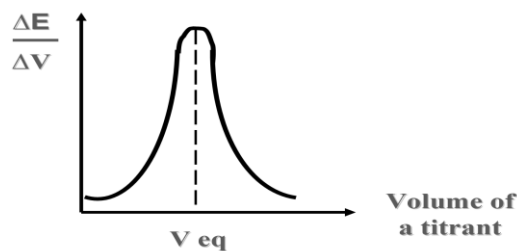

Figure 4 – Differential curve of potentiometric titration

Types of potentiometric titrations for the determination of analytes in test solutions include acid-base, redox, precipitation, and complexometric. Applications of potentiometric measurements are:

- analysis of colored and turbid solutions, pasts and gels;
- analysis of biological fluids without their destruction.

The experimental data can be received quickly and accurately (express analysis) [1, 3].

The practical part

Safety instructions before laboratory work.

LABORATORY WORK No. 1

Potentiometric titration of a weak acid solution

1. This procedure is based on the following chemical reaction:

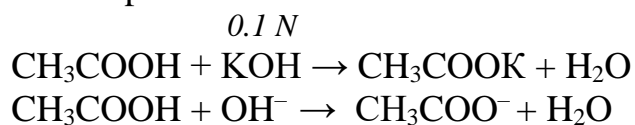

2. The cell diagram of the applied galvanic cell may be represented as follows:

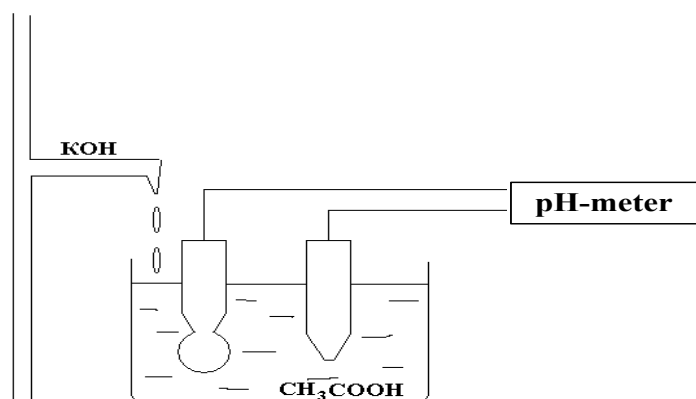
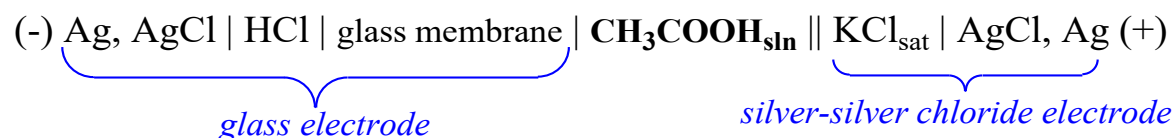

Figure 5 – Scheme of equipment for potentiometric titration

Carry out an experiment in the following sequence of operations:

- a) pour KOH solution (titrant) into the burette to the zero mark;
- b) pour 10 ml of the analyzed CH₃COOH solution into a titration glass using an analytical pipette; dip the glass and silver-silver chloride electrodes into the solution and measure the initial pH value of the solution (Fig. 5);
- c) titrate CH₃COOH solution by adding equal portions of KOH solution from the burette (volume of each portion is 1.00 ml); after adding each portion of the titrant, mix the solution thoroughly and measure the pH value of the solution;
- d) the end of the titration corresponds to the appearance of a titration jump in the pH values of the solution;
- e) record the measurement results in Table 2.

Table 2 – The results of potentiometric titration CH₃COOH solution against KOH solution

№	Total volume of KOH solution, ml	Volume of KOH solution added portion, ml	pH of solution
1.	0	0	
2.	1	1	
3.	2	1	
4.	3	1	
5.	4	1	
...			

3. Calculation of the results of the experiment:

a) in accordance with the data in the table, draw an integral curve of potentiometric titration (Fig. 6);

b) the equivalent volume of KOH is determined from the integral curve of potentiometric titration: from the middle of the titration jump (equivalence point), it is necessary to draw a perpendicular to the volume axis (this will be the equivalent volume of the titrant);

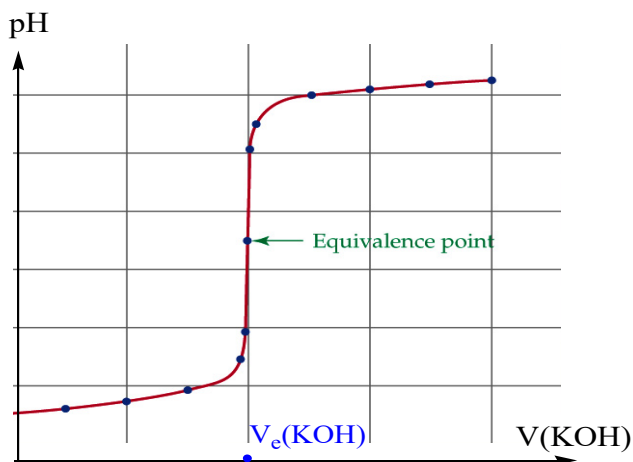

Figure 6 – Integral curve of potentiometric titration

c) according to the Equivalent Law in equivalence point:

$$n_e(\text{CH}_3\text{COOH}) = n_e(\text{KOH})$$

$$C_N(\text{CH}_3\text{COOH}) \times V(\text{CH}_3\text{COOH}) = C_N(\text{KOH}) \times V(\text{KOH})$$

$$C_N(\text{CH}_3\text{COOH}) = \frac{C_N(\text{KOH}) \times V(\text{KOH})}{V(\text{CH}_3\text{COOH})}$$

$C_N(\text{KOH})$ – normality of KOH solution, mol/l;

$V(\text{KOH})$ – KOH equivalent volume, ml;

$V(\text{CH}_3\text{COOH})$ – volume of acetic acid, ml.

LABORATORY WORK No. 2

Determination of acetic acid ionization constant (K_a)

1. Half of the equivalent volume of KOH is added to 10.0 ml of acetic acid solution and the pH value is measured. As a result of this procedure, half of the acid will be neutralized, thus half of the CH_3COOH will be converted into its salt.

Since in this case $[\text{CH}_3\text{COOH}] = [\text{CH}_3\text{COONa}]$,

$$K_a = \frac{[\text{CH}_3\text{COO}^-] \times [\text{H}^+]}{[\text{CH}_3\text{COOH}]}, \quad K_a = [\text{H}^+]; \quad -\log K_a = -\log[\text{H}^+]; \quad pK_{a(\text{exp})} = \text{pH} =$$

2. Compare the $\text{p}K_a$ value of acetic acid obtained experimentally with the $\text{p}K_a$ value taken from the Reference book. Calculate the absolute and relative errors of the experiment:

$$D = |pK_{a(\text{exp})} - pK_{a(\text{true})}| =$$

$$pK_{a(\text{true})} = 4.75$$

$$D_0 = \frac{D}{pK_{a(\text{true})}} \times 100\%$$

Control over the assimilation of the topic

It is conducted in the form of an oral conversation with students.

QUESTIONS FOR SELF-CONTROL OF KNOWLEDGE

1. The reduction potential is a measure of the strength of oxidants and reducing agents in aqueous solutions. The Nernst equation for calculating potential values. Calculations of the electromotive force, the change in Free Energy, and the equilibrium constant for any redox reaction.

2. Galvanic cells (chemical and concentration): structure and operation; calculation of EMF. Electrode and diffusion potentials. Galvanic cell diagrams. Calculation of the EMF of a galvanic cell. Membranes (biopotentials), their calculation.

3. Potentiometry: direct (pH determination) and indirect (potentiometric titration). Types of electrodes used in potentiometry: metal electrodes, gas electrodes, metal-insoluble salt electrodes, ion-selective electrodes. Indicator and reference electrodes.

Exercises for the self – control

1. Which of the following is the strongest oxidizing agent:

a) H_2O_2 in acidic medium: $\varphi^\circ (\text{H}_2\text{O}_2 | \text{H}_2\text{O}) = +1.77 \text{ B}$

b) H_2O_2 in basic medium: $\varphi^\circ (\text{H}_2\text{O}_2 | 2\text{OH}^-) = +0.88 \text{ B}$

c) MnO_4^- in acidic medium: $\varphi^\circ (\text{MnO}_4^- | \text{Mn}^{2+}) = +1.51 \text{ B}$

d) MnO_4^- in basic medium: $\varphi^\circ (\text{MnO}_4^- | \text{MnO}_4^{2-}) = +0.56 \text{ B}$

e) CrO_4^{2-} in acidic medium: $\varphi^\circ (\text{Cr}_2\text{O}_7^{2-} | 2\text{Cr}^{3+}) = +1.33 \text{ B?}$

2. Calculate the redox potential for the system:

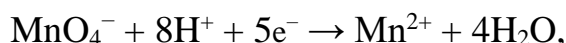

if $C_{\text{M}}(\text{MnO}_4^-) = 10^{-5} \text{ mol/l}$; $C_{\text{M}}(\text{Mn}^{2+}) = 10^{-2} \text{ mol/l}$; $C_{\text{M}}(\text{H}^+) = 0.2 \text{ mol/l}$

Answer: 1.41 V

3. Is it possible spontaneous running of the redox reaction under standard conditions:

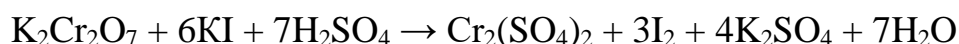

$\varphi^\circ (\text{Cr}_2\text{O}_7^{2-} | 2\text{Cr}^{3+}) = +1.33 \text{ V}$

$\varphi^\circ (\text{I}_2 | 2\text{I}^-) = +0.54 \text{ V?}$

Answer: $E^0 = 1.41 \text{ V}$ (positive value), spontaneous process under standard conditions

4. Calculate the EMF of the galvanic cell: $\text{Al} | \text{Al}^{3+} || \text{Cu}^{2+} | \text{Cu}$ if

$C_{\text{M}}(\text{Al}^{3+}) = 10^{-3} \text{ mol/l}$, $\varphi^\circ (\text{Al}^{3+} | \text{Al}) = -1.66 \text{ B}$;

$C_{\text{M}}(\text{Cu}^{2+}) = 10^{-2} \text{ mol/l}$, $\varphi^\circ (\text{Cu}^{2+} | \text{Cu}) = +0.337 \text{ B}$.

Answer: 1.996 V

QUESTIONS FOR INDEPENDENT WORK OF STUDENTS (IWS)

1. Two types of membrane potential in biological systems (resting membrane potential and action potential) and their functional significance.
2. Potentiometric titration, its essence and use in quantitative analysis and biomedical research.

LIST OF SOURCES USED

1. Medical chemistry : textbook for students of higher education establishments – med. univ., inst. and acad. / V.O. Kalibabchuk, V.I. Halynska, L.I. Hryshchenko et al. ; ed. by V.O. Kalibabchuk. – 6th ed., corr. – Kyiv : AUS Medicine Publishing, 2018. – P. 92-107.

2. Основы химии для иностранных студентов = Essential chemistry for foreign students : учебно-методическое пособие / С. В. Ткачѳв [и др.]. – 5-е изд. – Минск : БГМУ, 2018. – С. 121-136. – Режим доступа: <http://rep.bsmu.by:8080/handle/BSMU/21054>.

3. Филиппова, В. А. Общая химия : учеб. пособие для студентов лечеб. факта, обуч. на англ. яз. : в 2 ч. = General Chemistry : Educational guidance for students medical department in English medium / В. А. Филиппова, А. В. Лысенкова, Л. В. Чернышева. – Гомель : ГомГМУ, 2009. – Ч. 1. – 192 с. URI: <https://elib.gsmu.by/handle/GomSMU/2679>.